

BASO 2.5 PERIMETER / COVE

MOUNTING INSTRUCTIONS

DO NOT DISCARD!

SIGN LEGEND



POWER OFF



ATTENTION



POWER ON



USE ESD GLOVES



DON'T TOUCH THE LED

TOOLS REQUIRED (not included)



Pencil



Level



Screwdriver



ESD gloves

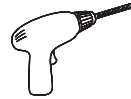

Drill

trimless

flush

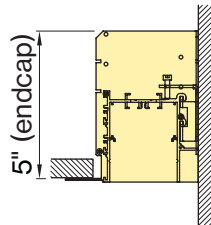
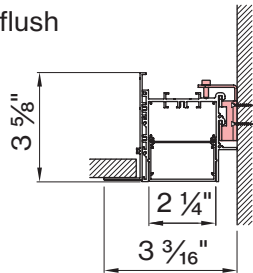

Fixture needs to be installed before ceiling is in place

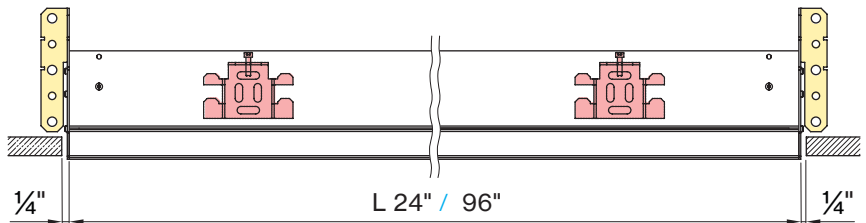

regressed 1"

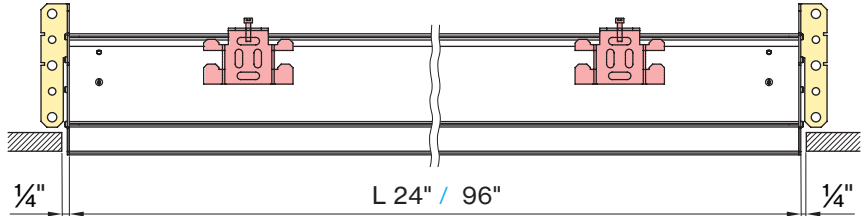
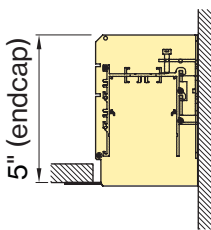
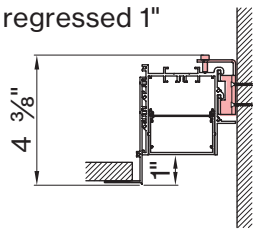

regressed 2"

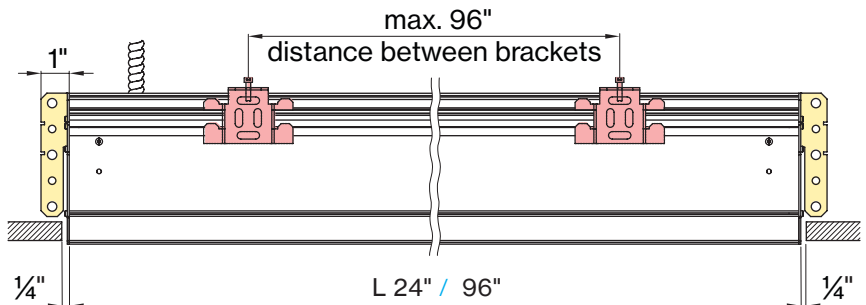
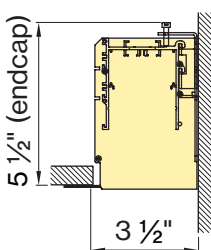
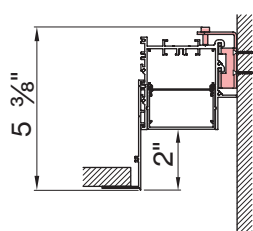

mounting bracket

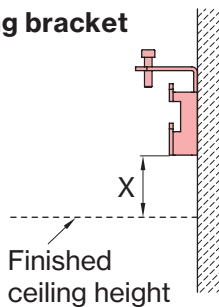

distance between mounting bracket to ceiling

flush

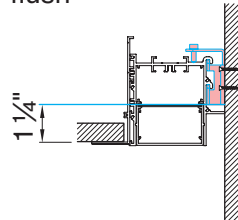

regressed 1"

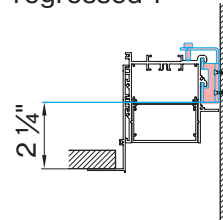

regressed 2"

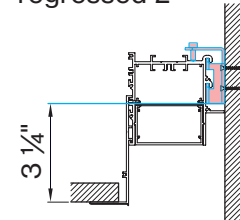

BASO 2.5 PERIMETER / COVE

MOUNTING INSTRUCTIONS

with trim

flush

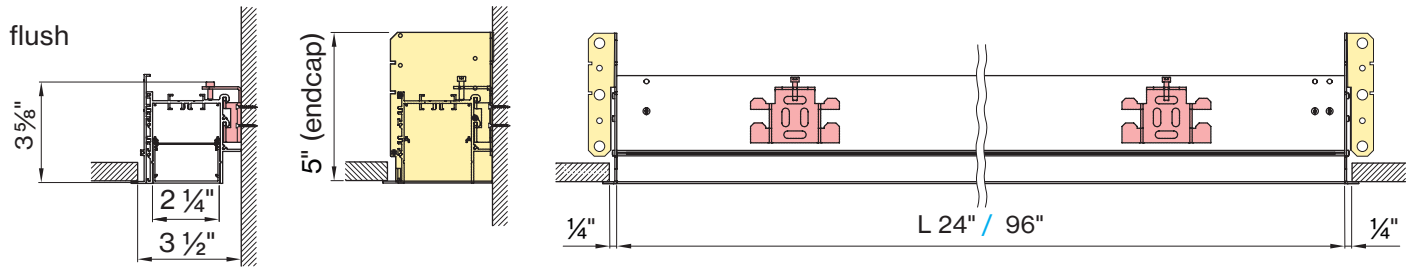

regressed 1"

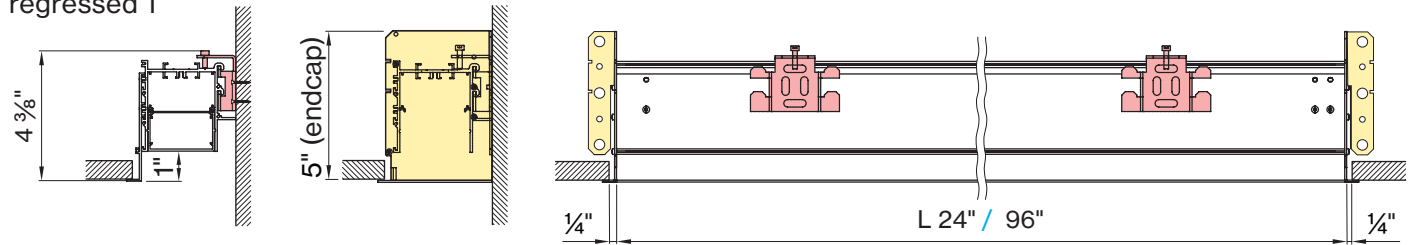

regressed 2"

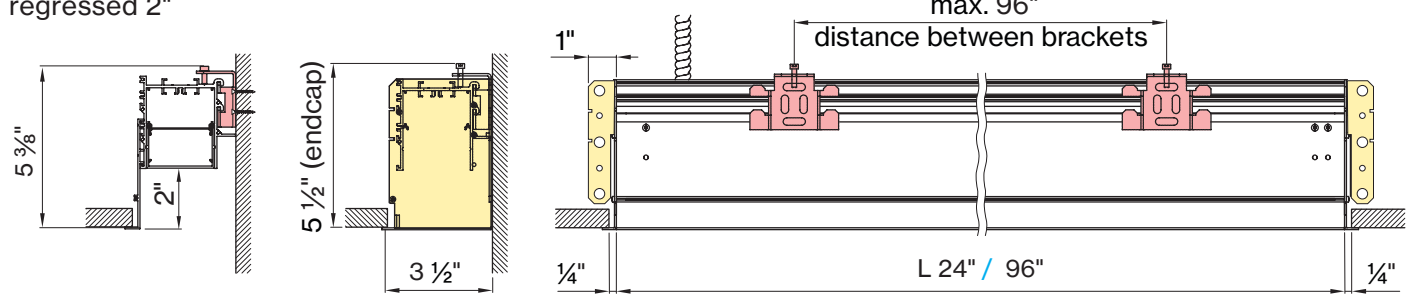

mounting bracket

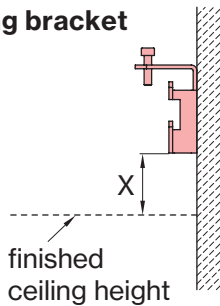

distance between mounting bracket to ceiling

flush

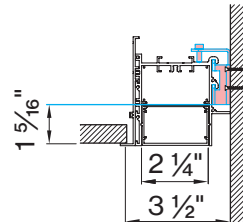

regressed 1"

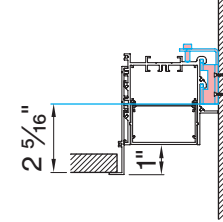

regressed 2"

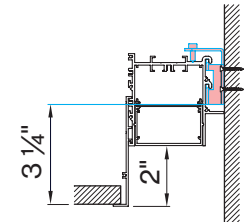

1. Measure desired location on wall for mounting bracket. See "distance between mounting bracket to ceiling" above for value of X

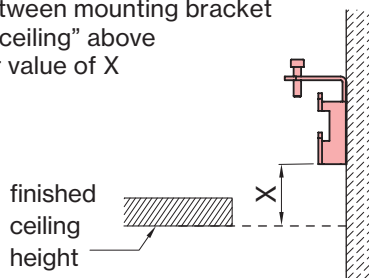

2. Distance between bracket to edge should be about 6 inches

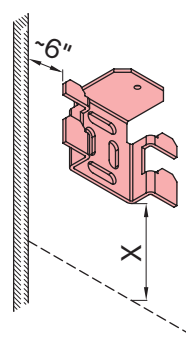

3. top view

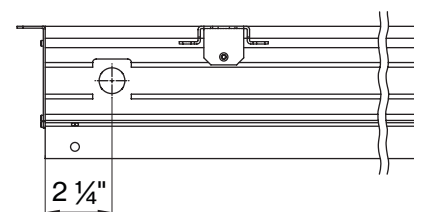

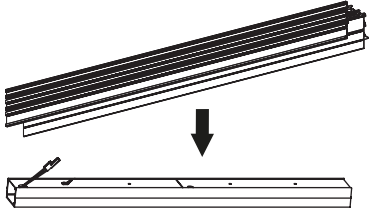
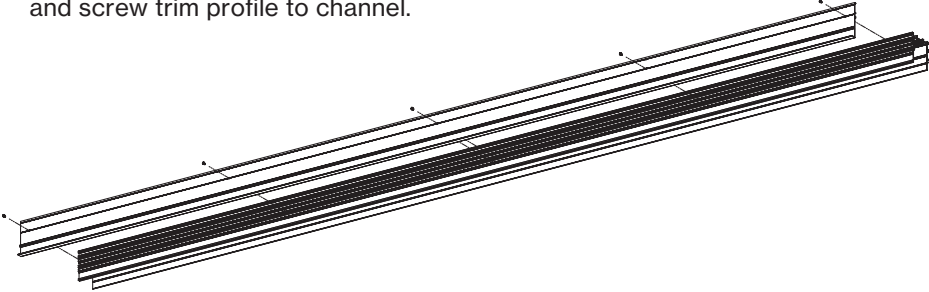
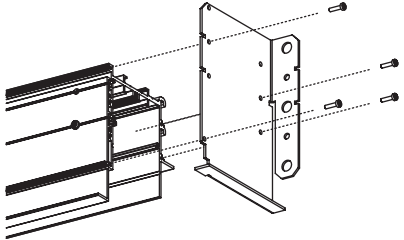
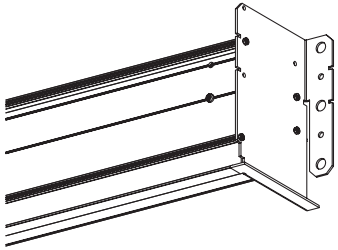
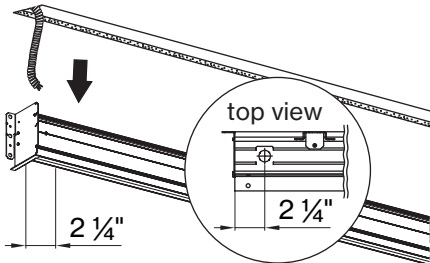
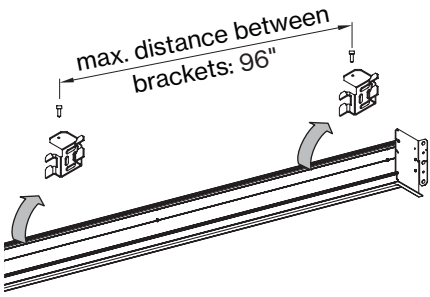
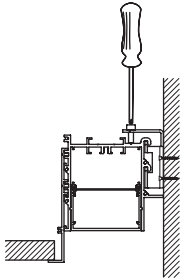
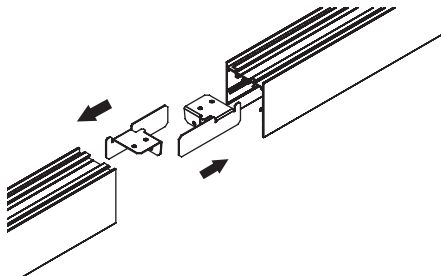
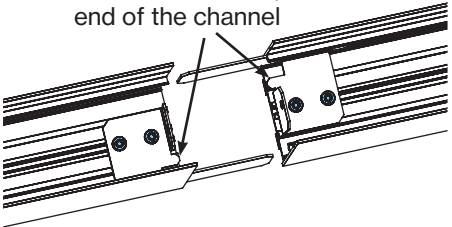
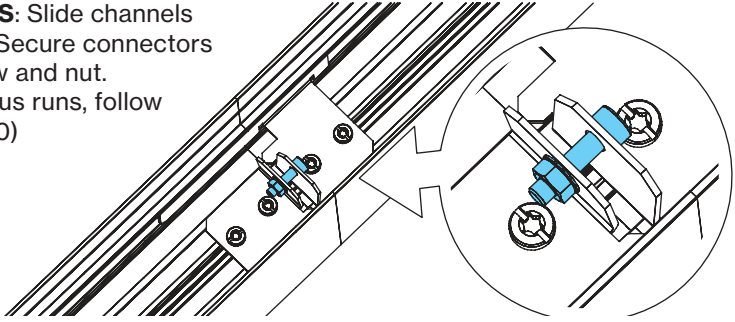
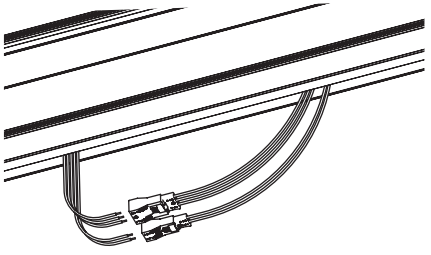

BASO 2.5 PERIMETER / COVE

MOUNTING INSTRUCTIONS

<p>4.</p> <p>Fixture needs to be installed before ceiling is in place</p>	<p>5. Remove inset(s) and cover from channel(s)</p> 	<p>6.</p> <p>Do not touch the LEDs! The electrostatic discharge could damage them. Wear ESD protective clothing.</p>
<p>7. Select the desired height (flush, 1" recessed or 2" recessed) and screw trim profile to channel.</p> 	<p>8. Screw end caps to channel</p> 	
<p>9.</p> 	<p>10. Thread conduit through top of channel. Conduit supplied by others.</p> 	<p>11. Hang channel onto mounting brackets</p> <p>max. distance between brackets: 96"</p> 
<p>12. Tighten screws on top of brackets</p> 	<p>13. For continuous runs: Slide next channel onto linear connector</p> 	<p>14. For continuous runs: Use screws to secure linear connector</p> <p>tab should not be past end of the channel</p> 
<p>15. SYSTEMS: Slide channels together. Secure connectors with screw and nut. (continuous runs, follow steps 6-10)</p> 	<p>16. Establish primary connection to feeder</p> 	

BASO 2.5 PERIMETER / COVE

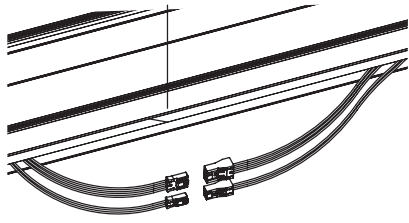
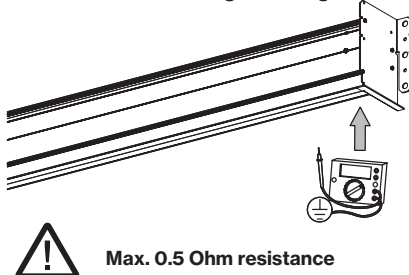
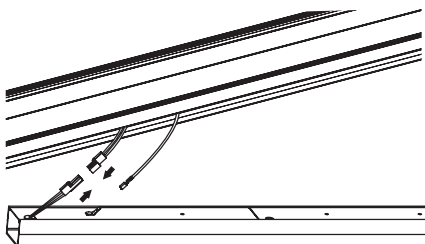
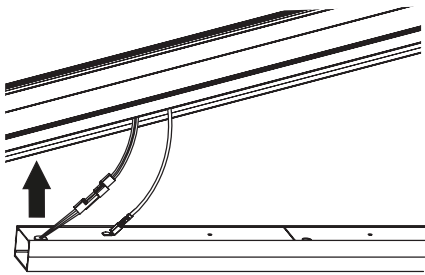
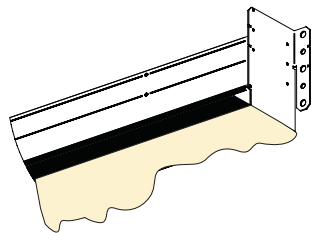
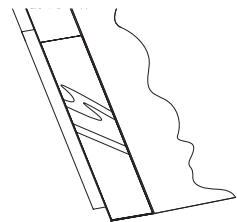
MOUNTING INSTRUCTIONS

<p>17. Establish connection between segments</p> 	<p>18. Test the channel grounding</p>  <p>Max. 0.5 Ohm resistance</p>	<p>19. Connect inset(s) wiring and grounding to channel(s)</p> 
<p>20. Insert inset / cover</p> 	<p>21. Mud, sand, and paint ceiling. Installation complete</p> 	<p>22. Installation complete</p>  <p> *Please see wiring Diagram on next page.</p>

Technical Support Hotline

Call the BASO Technical Support Hotline from Monday to Friday, 8 AM - 6 PM (EST)

Hotline:
+1 203 262 9990

Or 24/7 via email:
service@xalusa.com

EN Installation, commissioning and maintenance may only be performed by authorized and qualified personnel, taking into consideration these installation instructions and any standards and regulations applicable to the respective area of application. The electrical, mechanical and thermal suitability of the luminaire for the intended area of application must be ensured and the secure fastening of the luminaire after its installation must be controlled. Turn off supply voltage before replacing any lamps (if applicable) as well as before performing any other works on the luminaire (e.g. cleaning) and wait until luminaire and lamp have completely cooled off. Please refer to the installation notes of the lamp manufacturer when inserting, replacing and operating conventional lamps. Use a soft, damp cloth to clean the luminaire. To clean plastic components and reflectors, a standard pH neutral, alcohol-free, non-abrasive cleaning agent may also be used. Keep these installation instructions in a safe place as reference for any future maintenance works.

1. The lamp is not suitable for outdoor use.
2. The lamp may only be used with a safety guard.
3. Damaged protection glasses and covers have to be replaced immediately.
4. Corrosive chemical products must not be used as this may have a detrimental effect on the luminaire.
5. No liability is accepted for any subsequent change of the luminaire.
6. LEDs are high-quality electronic components! Please avoid touching by hand the LED light emitting surface while assembling or replacing parts and during maintenance work.
7. To avoid damage of the profile, unevenness on the wall or ceiling must be leveled out before assembling the profiles. While assembling the profiles, make sure they do not deform in order to guarantee their proper function.
8. The light source contained in this luminaire shall only be replaced by the manufacturer or his service agent or a similar qualified person.
9. The LED circuit must always be closed, before the converter is connected to the main power. XAL does not assume any liability for damages resulting from nonobservance of this rule.
10. Luminous flux and connected electrical load are subject to an initial tolerance of up to +/- 10%. Color temperature is subject to a tolerance of up to +/- 150 Kelvin from the nominal value.

FR Le montage et la maintenance peut être effectué par spécialistes respectant les normes y régles valides. Assurer l'aptitude thermique, mécanique et électrique pour l'emploi prévue et assurer la fixation de la luminaire. Éteindre la tension avant de changer les lampes (si applicable) ou avant de réaliser travaux (p.ex nettoyage) à la luminaire. Attendre jusqu'à ce que la luminaire et les lampes ont fraîchit complètement. Merci de bien vouloir vous référer aux notes d'installation du fabricant de la lampe lors de l'insertion, le remplacement et la mise en route, avec des lampes conventionnelles. Pour nettoyer la luminaire utiliser un drap humide et doux. Pour nettoyer les parties du plastique ou les réflecteurs peut utiliser encore un produit de nettoyage sans alcool qui ne fraye pas le material. Garder cette notice de montage pour possibles travaux de maintenance.

1. La luminaire n'est pas apte pour l'utilisation exterieur.
2. Utilizer la luminaire seulement avec un dispositif de sécurité
3. Changer immédiatement des verres de sécurité defectes ou bien des écrans de protection.
4. Evitez tout contact de la lampe avec de produits chimiques corrosifs.
5. Nous déclinons toute responsabilité en cas de modifications ultérieures.
6. Des LEDs sont des composants électroniques de haute qualité! Eviter tout contact direct de la surface de sorti de lumière de la LED avec les mains lors du montage ou des travaux de maintenance de la lampe.
7. Pour éviter l'endommagement du profil, il est nécessaire de compenser les irrégularités du mur ou du plafond avant le montage des profils. Pour garantir un fonctionnement irréprochable des profils, il ne faut pas déformer les profils lors du montage.
8. La source du luminaire peut être remplacé uniquement par le fabricant ou un tiers habilité.
9. Il faut que le circuit de LED soit fermé avant de connecter le convertisseur. XAL ne assume pas la garantie si cette norme ne se respecte pas.
10. La puissance et le flux lumineux affichent d'origine une tolérance de +/- 10 %. Tolérance de la couleur de température : +/- 150 Kelvin.

ES La instalación, la puesta en marcha y el mantenimiento sólo deben realizarse por personal especializado considerando esta guía de instalación y todas las normas y reglamentaciones vigentes. Asegurarse de la aptitud eléctrica, mecánica y térmica de la luminaria para la aplicación prevista y comprobar la fijación segura de la luminaria después de su instalación. Apagar siempre la corriente antes de cambiar la lámpara (en caso justificado) o de realizar algún otro trabajo en esta (p.ej. Limpieza). Esperar hasta que se enfrien la luminaria y la lámpara completamente. Tener en cuenta las instrucciones de montaje del fabricante al colocar, cambiar y utilizar lámparas convencionales. Para la limpieza de la luminaria utilizar un paño suave y húmedo. Para limpiar componentes de plástico y reflectores puede usar también un limpiador pH neutral y sin alcohol que no roce el material. Guardar esta guía de instalación para trabajos de mantenimiento.

1. La luminaria no es apta para utilizarla en el exterior.
2. La luminaria sólo debe accionar con un dispositivo de seguridad.
3. Cambie de inmediato los vidrios y las tapas de protección dañados.
4. Químicos que tienen efectos corrosivos no deben influir en la luminaria.
5. Para modificaciones futuras en la luminaria no se asume ninguna responsabilidad.
6. Los LED son componentes electrónicos de alta calidad! Por favor durante el montaje o el mantenimiento evite el contacto directo con la superficie de emisión.
7. Para evitar daños en el perfil, los desniveles de las paredes y techos deben ser enrasados antes del montaje de los perfiles. Para garantizar su buen funcionamiento, los perfiles no deben sufrir deformaciones durante el montaje.
8. La fuente luminosa contenida en esta luminaria debe ser reemplazada únicamente por el fabricante o su agente de servicio o similar persona cualificada.
9. El circuito LED debe ser cerrado antes de conectar el convertidor. XAL no asume garantía si esta norma no se respeta.
10. I dati di flusso luminoso e potenza sono inizialmente passibili di tolleranze di +/- 10%. Tolleranza della temperatura di colore: +/- 150 Kelvin.

We reserve the right to change our products at any time. Current information is available at www.xalusa.com.

Nos reservamos en todo momento el derecho de realizar cambios en nuestros productos. n nuestra página web www.xalusa.com siempre se encontrarán datos actuales.

Nous nous réservons le droit de modifier à tout moment nos produits. Vous trouverez toujours toutes les informations actuelles sur www.xalusa.com.

BASO 2.5 PERIMETER / COVE

MOUNTING INSTRUCTIONS

Wiring diagrams

Inset wiring without emergency circuit

no dimming

no emergency circuit

FEED

neutral (white)
ground (green)
phase (black)

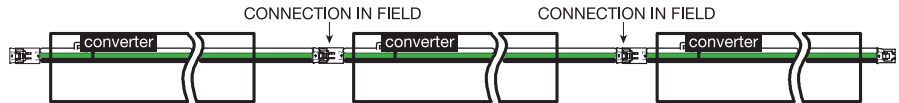

dim 0-10V (5%)

no emergency circuit

FEED

neutral (white)
ground (green)
phase (black)
dim + (violet)
dim - (gray)

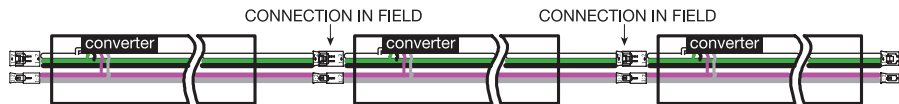

Hi-lume 3D (1%)

digital dim

no emergency circuit

FEED

neutral (white)
ground (green)
phase (black)
E1 (violet)
E2 (gray)

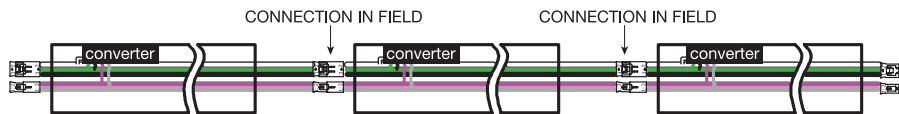

Inset wiring with emergency circuit

no dimming

with emergency circuit

FEED

neutral (white)
ground (green)
phase (black)
use phase for
Mark 10

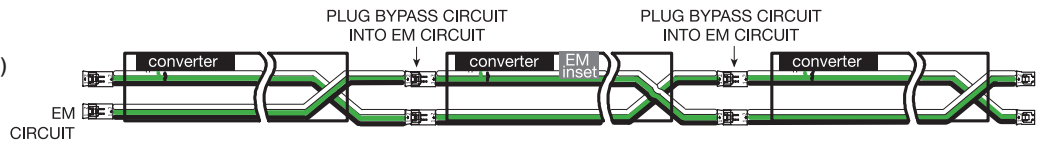

dim 0-10V (5%)

with emergency circuit

FEED

neutral (white)
ground (green)
phase (black)
dim + (violet)
dim - (gray)

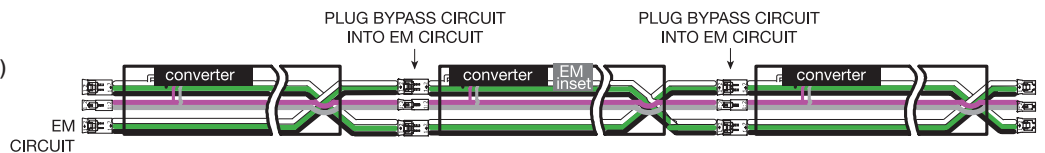

Hi-lume 3D (1%)

digital dim

with emergency circuit

FEED

neutral (white)
ground (green)
phase (black)
dim + (violet)
dim - (gray)

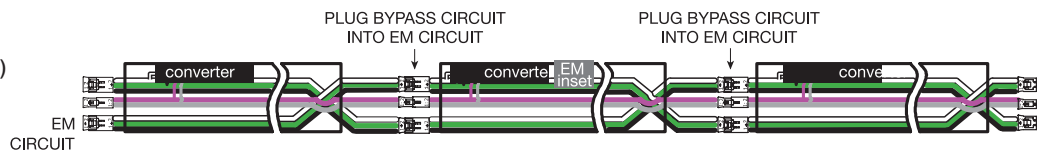

BASO 4.0 PERIMETER / COVE

MOUNTING INSTRUCTIONS

DO NOT DISCARD!

SIGN LEGEND



POWER OFF



ATTENTION



POWER ON



USE ESD GLOVES



DON'T TOUCH THE LED

TOOLS REQUIRED (not included)



Pencil



Level



Screwdriver



ESD gloves



Drill

trimless

regressed 2"

Fixture needs to be installed before ceiling is in place

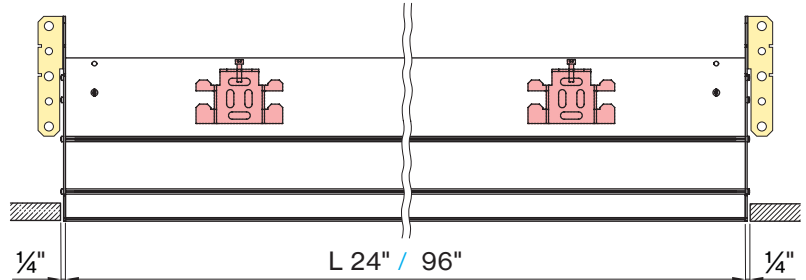
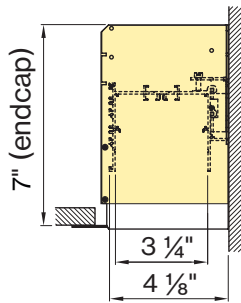
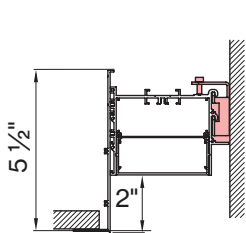

regressed 3"

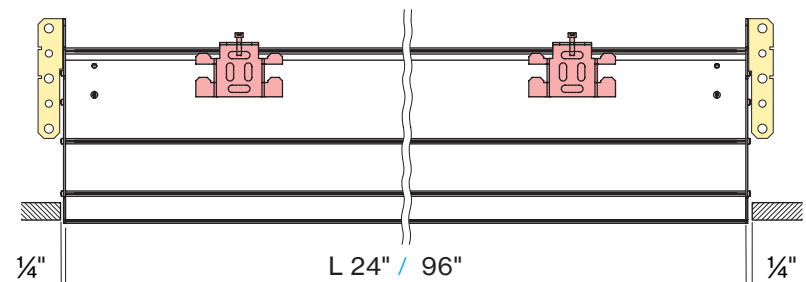
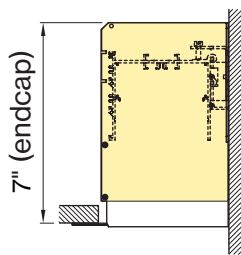
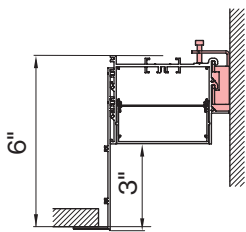

regressed 4"

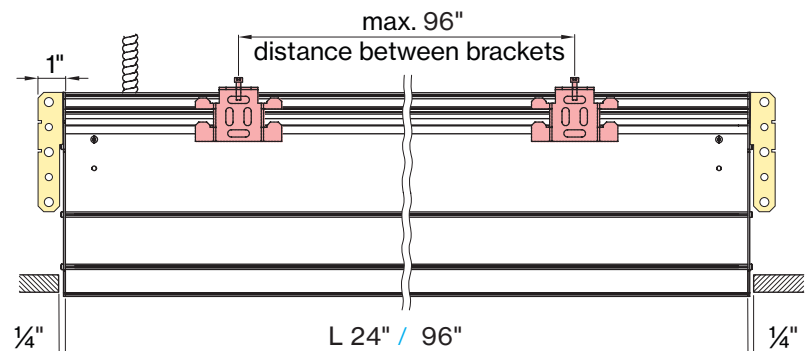
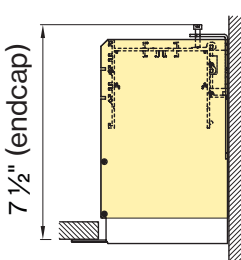
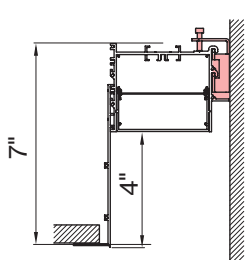

BASO 4.0 PERIMETER / COVE

MOUNTING INSTRUCTIONS

mounting bracket

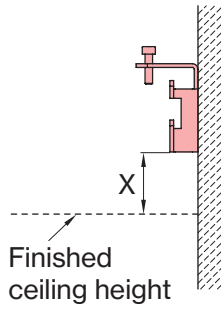

distance between mounting bracket to ceiling - trimless version

regressed 2"

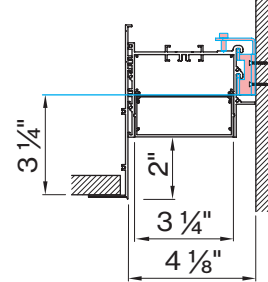

regressed 3"

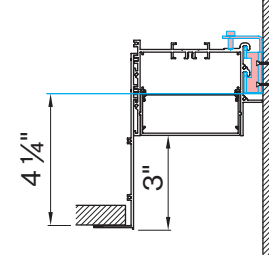

regressed 4"

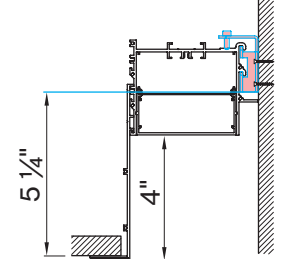

with trim

regressed 2"

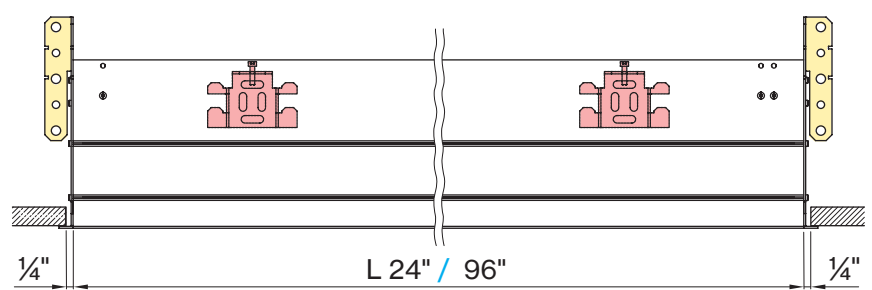
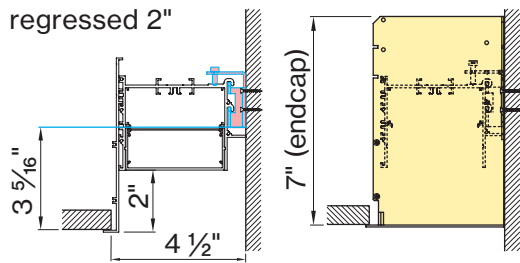

regressed 3"

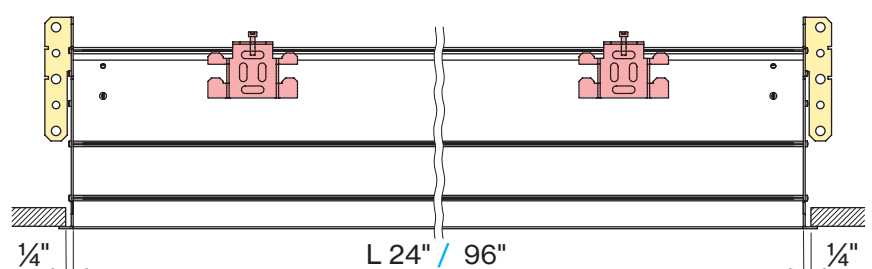
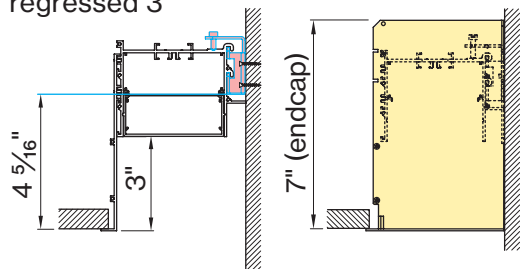

regressed 4"

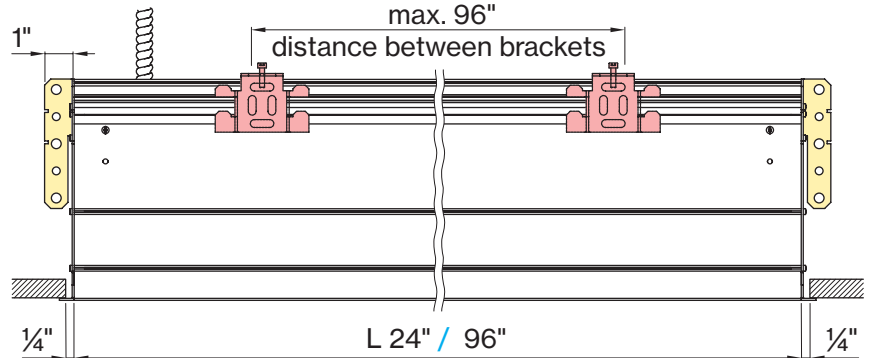
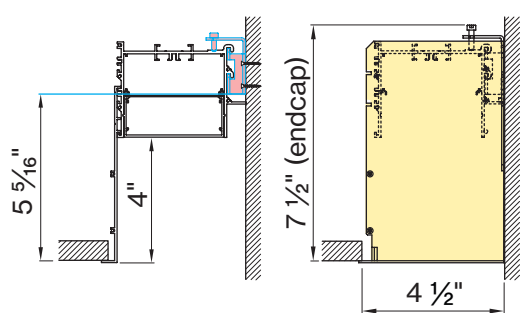

mounting bracket

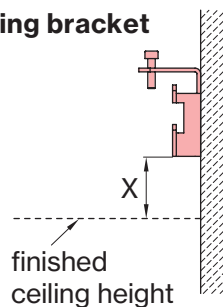

distance between mounting bracket to ceiling - trim version

regressed 2"

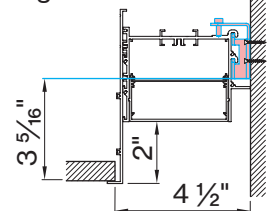

regressed 3"

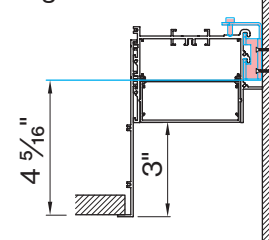

regressed 4"

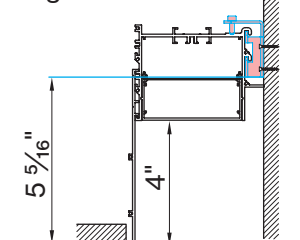

BASO 4.0 PERIMETER / COVE

MOUNTING INSTRUCTIONS

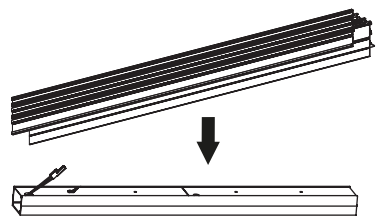
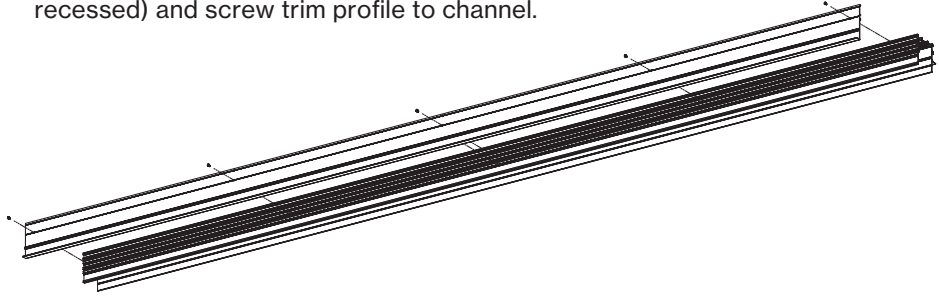
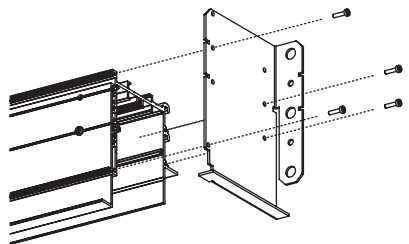
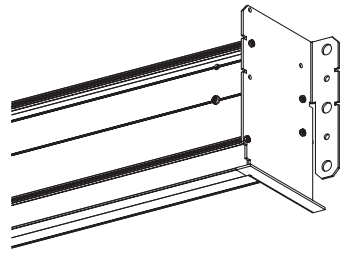
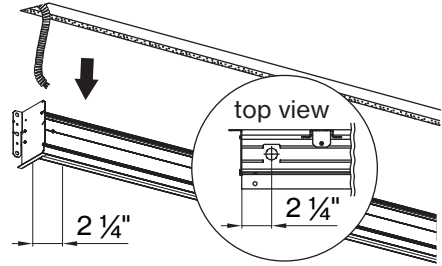
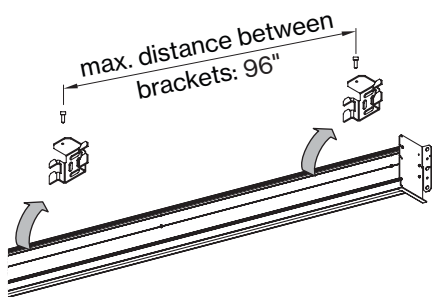
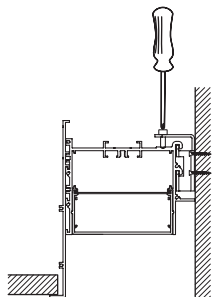
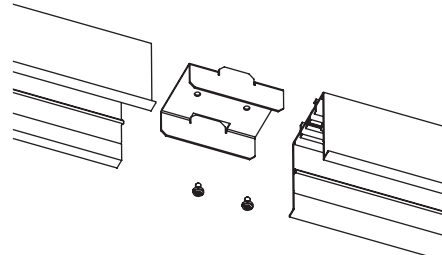
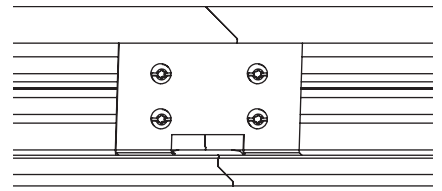
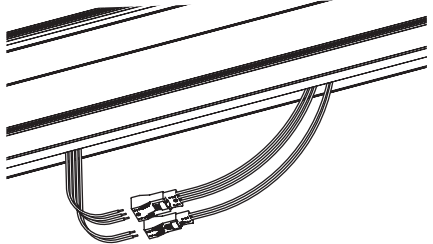
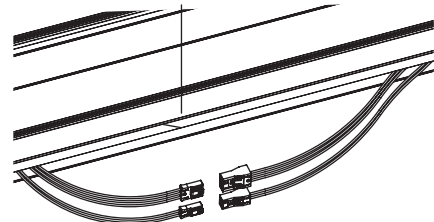
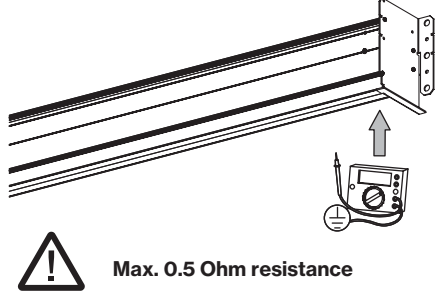
<p>4.</p> <p>Fixture needs to be installed before ceiling is in place</p>	<p>5. Remove inset(s) and cover from channel(s)</p> 	<p>6.</p> <p>Do not touch the LEDs! The electrostatic discharge could damage them. Wear ESD protective clothing.</p>
<p>7. Select the desired height (2" recessed, 3" recessed or 4" recessed) and screw trim profile to channel.</p> 		<p>8. Screw end caps to channel</p> 
<p>9.</p> 	<p>10. Thread conduit through top of channel. Conduit supplied by others.</p> 	<p>11. Hang channel onto mounting brackets</p> <p>max. distance between brackets: 96"</p> 
<p>12. Tighten screws on top of brackets</p> 	<p>13. For continuous runs: Slide next channel onto linear connector</p> 	<p>14. For continuous runs: Use screws to secure linear connector</p> 
<p>15. Establish primary connection to feeder</p> 	<p>16. Establish connection between segments</p> 	<p>17. Test the channel grounding</p>  <p>Max. 0.5 Ohm resistance</p>

BASO 4.0 PERIMETER / COVE

MOUNTING INSTRUCTIONS

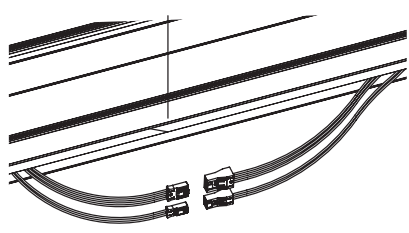
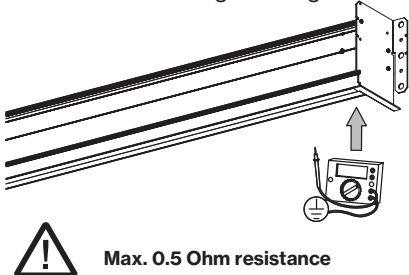
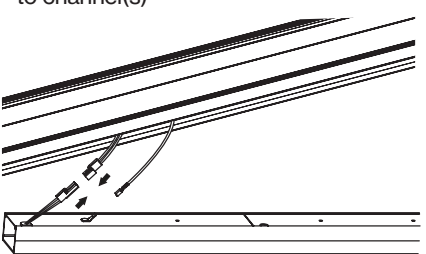
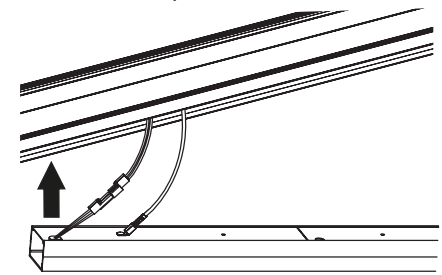
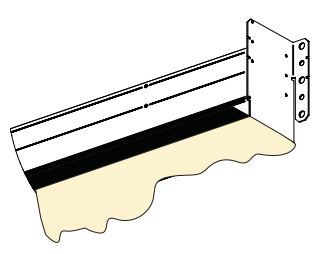
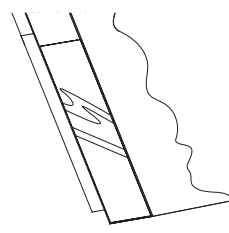
<p>17. Establish connection between segments</p> 	<p>18. Test the channel grounding</p>  <p>Max. 0.5 Ohm resistance</p>	<p>19. Connect inset(s) wiring and grounding to channel(s)</p> 
<p>20. Insert inset / cover</p> 	<p>21. Mud, sand, and paint ceiling. Installation complete</p> 	<p>22. Installation complete</p>  <p>*Please see wiring Diagram on next page.</p>

Technical Support Hotline

Call the BASO Technical Support Hotline from Monday to Friday, 8 AM - 6 PM (EST)

Hotline:
+1 203 262 9990

Or 24/7 via email:
service@xalusa.com

EN Installation, commissioning and maintenance may only be performed by authorized and qualified personnel, taking into consideration these installation instructions and any standards and regulations applicable to the respective area of application. The electrical, mechanical and thermal suitability of the luminaire for the intended area of application must be ensured and the secure fastening of the luminaire after its installation must be controlled. Turn off supply voltage before replacing any lamps (if applicable) as well as before performing any other works on the luminaire (e.g. cleaning) and wait until luminaire and lamp have completely cooled off. Please refer to the installation notes of the lamp manufacturer when inserting, replacing and operating conventional lamps. Use a soft, damp cloth to clean the luminaire. To clean plastic components and reflectors, a standard pH neutral, alcohol-free, non-abrasive cleaning agent may also be used. Keep these installation instructions in a safe place as reference for any future maintenance works.

- The lamp is not suitable for outdoor use.
- The lamp may only be used with a safety guard.
- Damaged protection glasses and covers have to be replaced immediately.
- Corrosive chemical products must not be used as this may have a detrimental effect on the luminaire.
- No liability is accepted for any subsequent change of the luminaire.
- LEDs are high-quality electronic components! Please avoid touching by hand the LED light emitting surface while assembling or replacing parts and during maintenance work.
- To avoid damage of the profile, unevenness on the wall or ceiling must be leveled out before assembling the profiles. While assembling the profiles, make sure they do not deform in order to guarantee their proper function.
- The light source contained in this luminaire shall only be replaced by the manufacturer or his service agent or a similar qualified person.
- The LED circuit must always be closed, before the converter is connected to the main power. XAL does not assume any liability for damages resulting from nonobservance of this rule.
- Luminous flux and connected electrical load are subject to an initial tolerance of up to +/- 10%. Color temperature is subject to a tolerance of up to +/- 150 Kelvin from the nominal value.

FR Le montage et la maintenance peut être effectué par spécialistes respectant les normes y régles valides. Assurer l'aptitude thermique, mécanique et électrique pour l'emploi prévue et assurer la fixation de la luminaire. Éteindre la tension avant de changer les lampes (si applicable) ou avant de réaliser travaux (p.ex nettoyage) a la luminaire. Attendre jusqu'à ce que la luminaire et les lampes ont fraîchit complètement. Merci de bien vouloir vous référer aux notes d'installation du fabricant de la lampe lors de l'insertion, le remplacement et la mise en route, avec des lampes conventionnelles. Pour nettoyer la luminaire utiliser un drap humide et doux. Pour nettoyer les parties du plastique ou les réflecteurs on peut utiliser encore un produit de nettoyage sans alcool qui ne fraye pas le material. Garder cette notice de montage pour possibles travaux de maintenance.

- La luminaire n' est pas apte pour l'utilizage exterieur.
- Utilizer la luminaire seulement avec un dispositif de sécurité
- Changer immédiatement des verres de sécurité defectes ou bien des écrans de protection.
- Evitez tout contact de la lampe avec de produits chimiques corrosifs.
- Nous déclinons toute responsabilité en cas de modifications ultérieures.
- Des LEDs sont des composants électroniques de haute qualité! Eviter tout contact direct de la surface de sorti de lumière de la LED avec les mains lors du montage ou des les travaux de maintenance de la lampe.
- Pour éviter l'endommagement du profil, il est nécessaire de compenser les irrégularités du mur ou du plafond avant le montage des profils. Pour garantir un fonctionnement irréprochable des profils, il ne faut pas déformer les profils lors du montage.
- La source du luminaire peut être remplace uniquement par le fabricant ou un tiers habilité.
- Il faut que le circuit de LED soit fermé avant de connecter le convertisseur. XAL ne assume pas la garantie si cette norme ne se respecte pas.
- La puissance et le flux lumineux affichent d'origine une tolérance de +/- 10%. Tolérance de la couleur de température : +/- 150 Kelvin.

ES La instalación, la puesta en marcha y el mantenimiento sólo deben realizarse por personal especializado considerando esta guía de instalación y todas las normas y reglamentaciones vigentes. Asegurarse de la aptitud eléctrica, mecánica y térmica de la luminaria para la aplicación prevista y comprobar la fijación segura de la luminaria después de su instalación. Apagar siempre la corriente antes de cambiar la lámpara (en caso justificado) o de realizar algún otro trabajo en esta (p.ej. Limpieza). Esperar hasta que se enfríen la luminaria y la lámpara completamente. Tener en cuenta las instrucciones de montaje del fabricante al colocar, cambiar y utilizar lámparas convencionales. Para la limpieza de la luminaria utilizar un paño suave y húmedo. Para limpiar componentes de plástico y reflectores puede usar también un limpiador pH neutral y sin alcohol que no roce el material. Guardar esta guía de instalación para trabajos de mantenimiento.

- La luminaria no es apta para utilizarla en el exterior.
- La luminaria sólo debe accionar con un dispositivo de seguridad.
- Cambie de inmediato los vidrios y las tapas de protección dañados.
- Químicos que tienen efectos corrosivos no deben influir en la luminaria.
- Para modificaciones futuras en la luminaria no se asume ninguna responsabilidad.
- Los LED son componentes electrónicos de alta calidad! Por favor durante el montaje o el mantenimiento evite el contacto directo con la superficie de emisión.
- Para evitar daños en el perfil, los desniveles de las paredes y techos deben ser enrasados antes del montaje de los perfiles. Para garantizar su buen funcionamiento, los perfiles no deben sufrir deformaciones durante el montaje.
- La fuente luminosa contenida en esta luminaria debe ser reemplazada únicamente por el fabricante o su agente de servicio o similar persona cualificada.
- El circuito LED debe ser cerrado antes de conectar el convertidor. XAL no asume garantía si esta norma no se respeta.
- Los datos de flujo luminoso y potencia son inicialmente pasibili de toleranze di +/- 10%. Tolleranza della temperatura di colore: +/- 150 Kelvin.

We reserve the right to change our products at any time. Current information is available at www.xalusa.com.

Nos reservamos en todo momento el derecho de realizar cambios en nuestros productos. n nuestra página web www.xalusa.com siempre se encontrarán datos actuales.

Nous nous réservons le droit de modifier à tout moment nos produits. Vous trouverez toujours toutes les informations actuelles sur www.xalusa.com.

BASO 4.0 PERIMETER / COVE

MOUNTING INSTRUCTIONS

Wiring diagrams

Inset wiring without emergency circuit

no dimming

no emergency circuit

FEED

neutral (white)
ground (green)
phase (black)

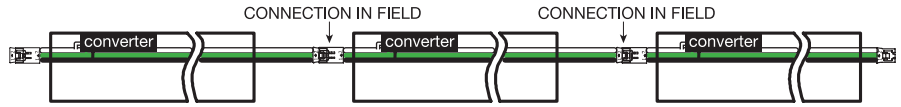

dim 0-10V (5%)

no emergency circuit

FEED

neutral (white)
ground (green)
phase (black)
dim + (violet)
dim - (gray)

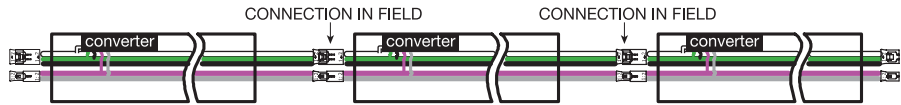

Hi-lume 3D (1%)

digital dim

no emergency circuit

FEED

neutral (white)
ground (green)
phase (black)
E1 (violet)
E2 (gray)

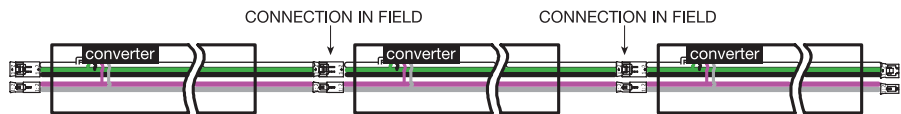

Inset wiring with emergency circuit

no dimming

with emergency circuit

FEED

neutral (white)
ground (green)
phase (black)
use phase for
Mark 10

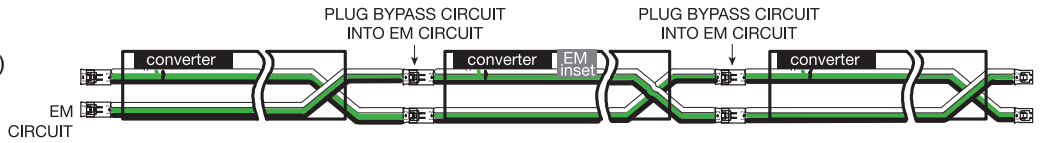

dim 0-10V (5%)

with emergency circuit

FEED

neutral (white)
ground (green)
phase (black)
dim + (violet)
dim - (gray)

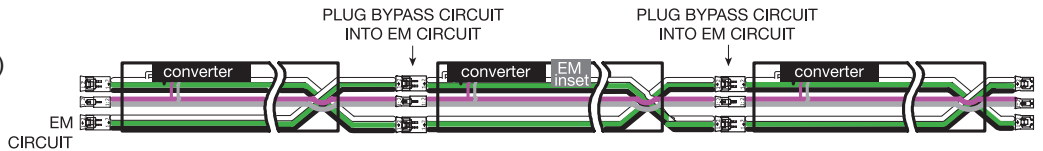

Hi-lume 3D (1%)

digital dim

with emergency circuit

FEED

neutral (white)
ground (green)
phase (black)
dim + (violet)
dim - (gray)

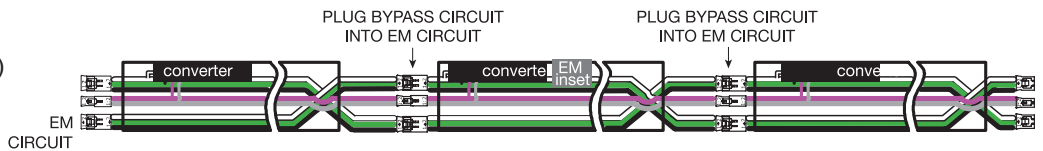

BASO 4.0 PERIMETER / COVE

MOUNTING INSTRUCTIONS

Technical Support Hotline

Call the BASO Technical Support Hotline from Monday to Friday, 8 AM - 6 PM (EST)

Hotline:
+1 203 262 9990

Or 24/7 via email:
service@xalusa.com

EN Installation, commissioning and maintenance may only be performed by authorized and qualified personnel, taking into consideration these installation instructions and any standards and regulations applicable to the respective area of application. The electrical, mechanical and thermal suitability of the luminaire for the intended area of application must be ensured and the secure fastening of the luminaire after its installation must be controlled. Turn off supply voltage before replacing any lamps (if applicable) as well as before performing any other works on the luminaire (e.g. cleaning) and wait until luminaire and lamp have completely cooled off. Please refer to the installation notes of the lamp manufacturer when inserting, replacing and operating conventional lamps. Use a soft, damp cloth to clean the luminaire. To clean plastic components and reflectors, a standard pH neutral, alcohol-free, non-abrasive cleaning agent may also be used. Keep these installation instructions in a safe place as reference for any future maintenance works.

1. The lamp is not suitable for outdoor use.
2. The lamp may only be used with a safety guard.
3. Damaged protection glasses and covers have to be replaced immediately.
4. Corrosive chemical products must not be used as this may have a detrimental effect on the luminaire.
5. No liability is accepted for any subsequent change of the luminaire.
6. LEDs are high-quality electronic components! Please avoid touching by hand the LED light emitting surface while assembling or replacing parts and during maintenance work.
7. To avoid damage of the profile, unevenness on the wall or ceiling must be leveled out before assembling the profiles. While assembling the profiles, make sure they do not deform in order to guarantee their proper function.
8. The light source contained in this luminaire shall only be replaced by the manufacturer or his service agent or a similar qualified person.
9. The LED circuit must always be closed, before the converter is connected to the main power. XAL does not assume any liability for damages resulting from nonobservance of this rule.
10. Luminous flux and connected electrical load are subject to an initial tolerance of up to +/- 10%. Color temperature is subject to a tolerance of up to +/- 150 Kelvin from the nominal value.

FR Le montage et la maintenance peut être effectué par spécialistes respectant les normes y régles valides. Assurer l'aptitude thermique, mécanique et électrique pour l'emploi prévue et assurer la fixation de la luminaires. Éteindre la tension avant de changer les lampes (si applicable) ou avant de réaliser travaux (p.ex nettoyage) a la luminaires. Attendre jusqu'à ce que la luminaires et les lampes ont fraîchit complètement. Merci de bien vouloir voir référer aux notes d'installation du fabricant de la lampe lors de l'insertion, le remplacement et la mise en route, avec des lampes conventionnelles. Pour nettoyer la luminaires utiliser un drap humide et doux. Pour nettoyer les parties du plastique ou les réflecteurs on peut utiliser encore un produit de nettoyage sans alcool qui ne fraye pas le matériel. Garder cette notice de montage pour possibles travaux de maintenance.

1. La luminaires n'est pas apte pour l'utilisation exterieur.
2. Utiliser la luminaires seulement avec un dispositif de sécurité
3. Changer immédiatement des verres de sécurité defectes ou bien des écrans de protection.
4. Evitez tout contact de la lampe avec de produits chimiques corrosifs.
5. Nous déclinons toute responsabilité en cas de modifications ultérieures.
6. Des LEDs sont des composants électroniques de haute qualité! Eviter tout contact direct de la surface de sorti de lumière de la LED avec les mains lors du montage ou des travaux de maintenance de la lampe.
7. Pour éviter l'endommagement du profil, il est nécessaire de compenser les irrégularités du mur ou du plafond avant le montage des profils. Pour garantir un fonctionnement irréprochable des profils, il ne faut pas déformer les profils lors du montage.
8. La source du luminaires peut être remplacé uniquement par le fabricant ou un tiers habilité.
9. Il faut que le circuit de LED soit fermé avant de connecter le convertisseur. XAL ne assume pas la garantie si cette norme ne se respecte pas.
10. La puissance et le flux lumineux affiché d'origine une tolérance de +/- 10%. Tolérance de la couleur de température : +/- 150 Kelvin.

ES La instalación, la puesta en marcha y el mantenimiento sólo deben realizarse por personal especializado considerando esta guía de instalación y todas las normas y reglamentaciones vigentes. Asegurarse de la aptitud eléctrica, mecánica y térmica de la luminaria para la aplicación prevista y comprobar la fijación segura de la luminaria después de su instalación. Apagar siempre la corriente antes de cambiar la lámpara (en caso justificado) o de realizar algún otro trabajo en esta (p.ej. Limpieza). Esperar hasta que se enfrien la luminaria y la lámpara completamente. Tener en cuenta las instrucciones de montaje del fabricante al colocar, cambiar y utilizar lámparas convencionales. Para la limpieza de la luminaria utilizar un paño suave y húmedo. Para limpiar componentes de plástico y reflectores puede usar también un limpiador pH neutral y sin alcohol que no roce el material. Guardar esta guía de instalación para trabajos de mantenimiento.

1. La luminaria no es apta para utilizarla en el exterior.
2. La luminaria sólo debe accionar con un dispositivo de seguridad.
3. Cambie de inmediato los vidrios y las tapas de protección dañados.
4. Químicos que tienen efectos corrosivos no deben influir en la luminaria.
5. Para modificaciones futuras en la luminaria no se asume ninguna responsabilidad.
6. Los LED son componentes electrónicos de alta calidad! Por favor durante el montaje o el mantenimiento evite el contacto directo con la superficie de emisión.
7. Para evitar daños en el perfil, los desniveles de las paredes y techos deben ser enrasados antes del montaje de los perfiles. Para garantizar su buen funcionamiento, los perfiles no deben sufrir deformaciones durante el montaje.
8. La fuente luminosa contenida en esta luminaria debe ser reemplazada únicamente por el fabricante o su agente de servicio o similar persona calificada.
9. El circuito LED debe ser cerrado antes de conectar el convertidor. XAL no asume garantía si esta norma no se respeta.
10. I dati di flusso luminoso e potenza sono inizialmente passibili di tolleranze di +/- 10%. Tolleranza della temperatura di colore: +/- 150 Kelvin.

We reserve the right to change our products at any time. Current information is available at www.xalusa.com.

Nos reservamos en todo momento el derecho de realizar cambios en nuestros productos. En nuestra página web www.xalusa.com siempre se encontrarán datos actuales.

Nous nous réservons le droit de modifier à tout moment nos produits. Vous trouverez toujours toutes les informations actuelles sur www.xalusa.com.

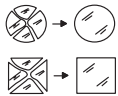

The lamp may only be operated with its full protective cover!

L'apparechio necessita del relativo vetro di protezione!

Sólo usar la luminaria con su cobertura de seguridad completa!



Recommended room temperature: 77 °F.
Temperatura ambiente recomendada: 77 °F.
Température ambiante recommandée: 77 °F.



Don't touch the LED



Use gloves.
Use guantes.
Utiliser des gants.